

Flemings



96 Boorowa Street Koorawatha NSW

4  1  4 

Flemings Cowra is pleased to present 96 Boorowa Street, Koorawatha to the market for sale.

A large four bedroom home located in a quiet semi rural setting awaits for its new owners to enjoy all it has to offer.

Features include:

- Spacious sunken lounge room with cosy wood heating
- Central kitchen and dining areas with direct access to the covered 6m* x 5m* entertaining deck
- All four bedrooms have the luxury of built in wardrobes whilst the main bedroom also boasts reverse cycle air conditioning
- Ducted evaporative cooling
- Shedding to include 6m* x 7m* garage/shed and a 9m* x 5.5m* double carport
- Centrally positioned 27.3km* to Cowra and 44.3km* to

Price : \$430,000
Land Size : 2023 sqm
View : <https://www.flemingspropertyservices.com/sale/nsw/central-west/koorawatha/residential/house/8040153>



Andrew Molloy
(02) 6342 6880

<https://www.flemingspropertyservices.com>

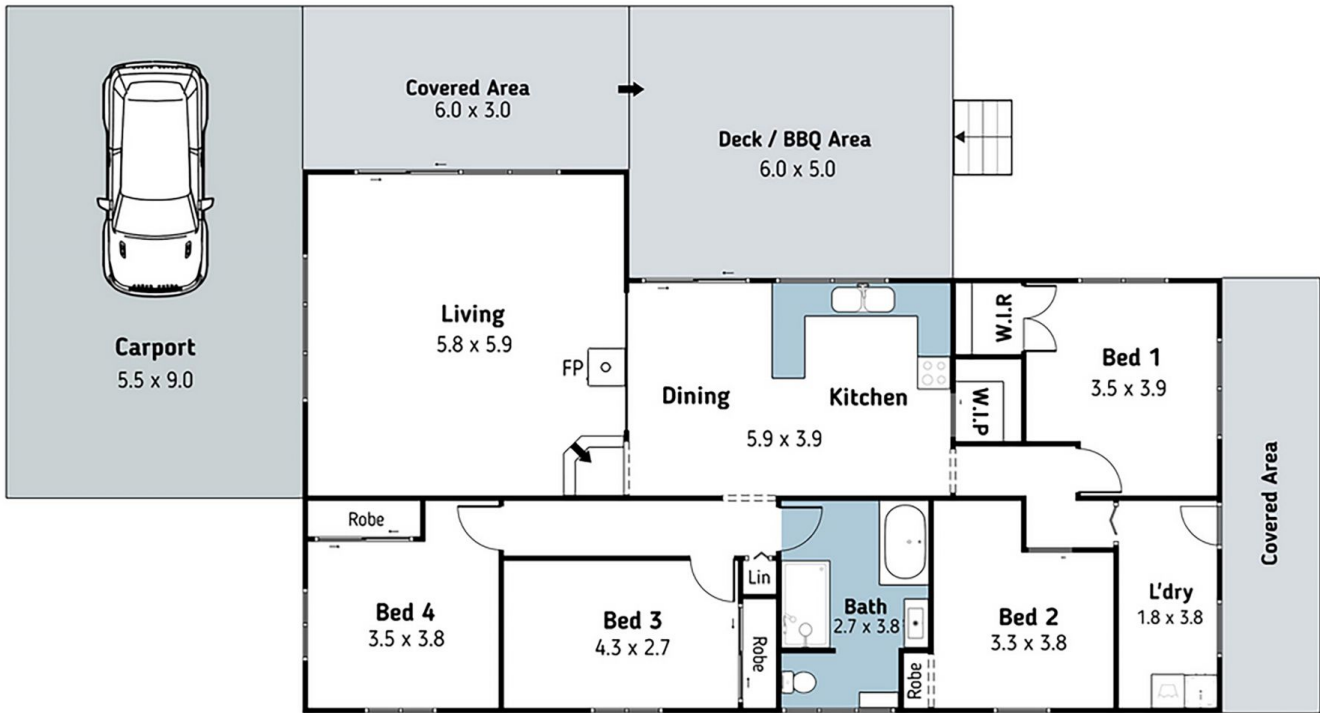

Flemings

96 Boorowa St, Koorawatha NSW 2807

Total Approx Floor Area = 145.2 SQ.M

Whilst every attempt has been made to ensure the accuracy of the floor plan contained here, measurements of doors, windows, rooms and any other items are approximate and no responsibility is taken for any omission, or mis statement. This plan is for illustrative purposes only and should be used as such by any prospective purchaser

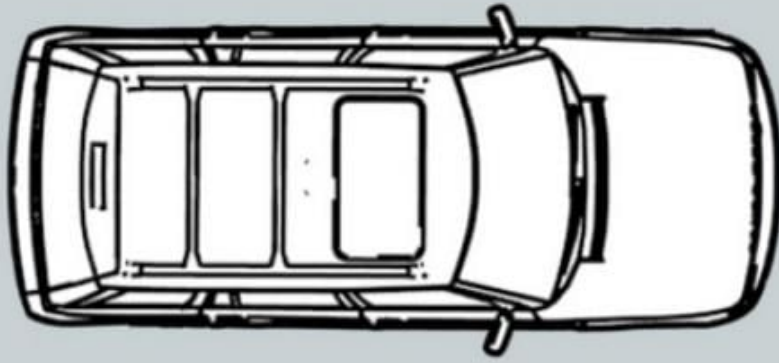

Garage

6.0 x 7.0

